

EK20R(EK20RL)

Electric Counterbalanced Forklift

Manual



Note Please read this manual before using!

Note Please do not use it before completing the installation!

Introduction

In order to meet the needs of the national environmental protection request, To reduce industrial pollution and improve productivity, we design and produce new series of EK20R(EK20RL) type Counterbalanced forklift on the basis of absorption of the advantages of domestic & overseas Electric forklift ,they are especially suitable for cargo loading and unloading, handling, stacking, etc for food, bank, light textile, station, port, logistics and other enterprises. And it can apply widely if inter-grate with different fixture

The Electric forklift adopt wild-field lifting system ,EPS system , new AC controller and Open type lamp holder .It is equipped high-quality Motors, Battery, and high-power pumping stations .Therefor it is Convenient operation .With Good view, Flexible steering ,Reliable braking ,Good power, Low noise, No pollution and Attractive appearance .

This manual describes the technical parameters of the Counterbalanced Electric Forklift , working principle and operation, maintenance, and other aspects. It can help operators use the Counterbalanced Electric Forklift more reasonable, make its maximum effect.

It is hoped that Operator strictly abide the regulations and the precautions in this manual when using the machine. Carefully use them so that your Forklift can be in the best working condition for long period of time to maximize its effectiveness. And create better economic benefits.

The Statement

Our company production model EK20R(EK20RL) type Counterbalanced Electric Forklift is a special motor vehicle used in Factory ,Tourist attractions ,Amusement places which is specified by “special equipment safety supervision regulations”

Contents

1.General Introduction	1
2.Proper usage	2
3..Introduction of the product.....	4
3.1Model overview	4
3.2Product Schematic diagram&Parameter	4
4.The Schematic diagram of Operating Mechanism	5
5.Structure ,Principle and Adjustment of main parts of forklift	7
5.1Drive system	8
5.2Steering system	9
5.3 Brake structure &Brake Schematic.....	12
5.4 Operating system	21
5.5 Electric system.....	22
5.6 Hyraulic system	24
6.Electrical Schematic diagram.....	25
7.Hydraulic Schematic diagram.....	26
8.Operating Specification.....	27
8.1 Sart ,Running and Parking	27
8.2 Steering wheel angle front and rear adjustment.....	28
8.3 Pedal accelerator operation.....	28
8.4 Pedal brake operation.....	28
8.5Use of emergency power off safety switch	28
8.6 Use of Horn and Reversing horn.....	28
8.7 Hydraulic joystick operation.....	29
8.8 Battery display	29
8.9 Handling & Stacking operation.....	29
9.Maintain Introduction	30

9.1 Repair & Maintenance Safety procedure	30
9.2 Routine Maintenance	31
9.3 Professional Maintenance manual	31
9.4 Maintenance ,Recharging and replacement of the Accumulator	34
10.Safety Operation And Cautions	42
10.1General Rul	42
10.2 Transportation & Storage	42
10.3 Check before using.....	43
10.4Safety Operation Rules.....	43
11.Toubleshooting.....	46
11.1Hand and foot brake common faults and troubleshooting	46
11.2Steering system common faults and troubleshooting	47
11.3Lifting system common faults and troubleshooting	48
11.4Electric system common faults and troubleshooting	49
11.5Gearbox failure reasons and troubleshooting.....	50
11.6Multi-way valve failure reasons and troubleshooting	50
11.7Gear pump failure reasons and troubleshooting.....	52
11.8Other common faults and troubleshooting.....	54
12.Aftersales	55

1、 General Introduction

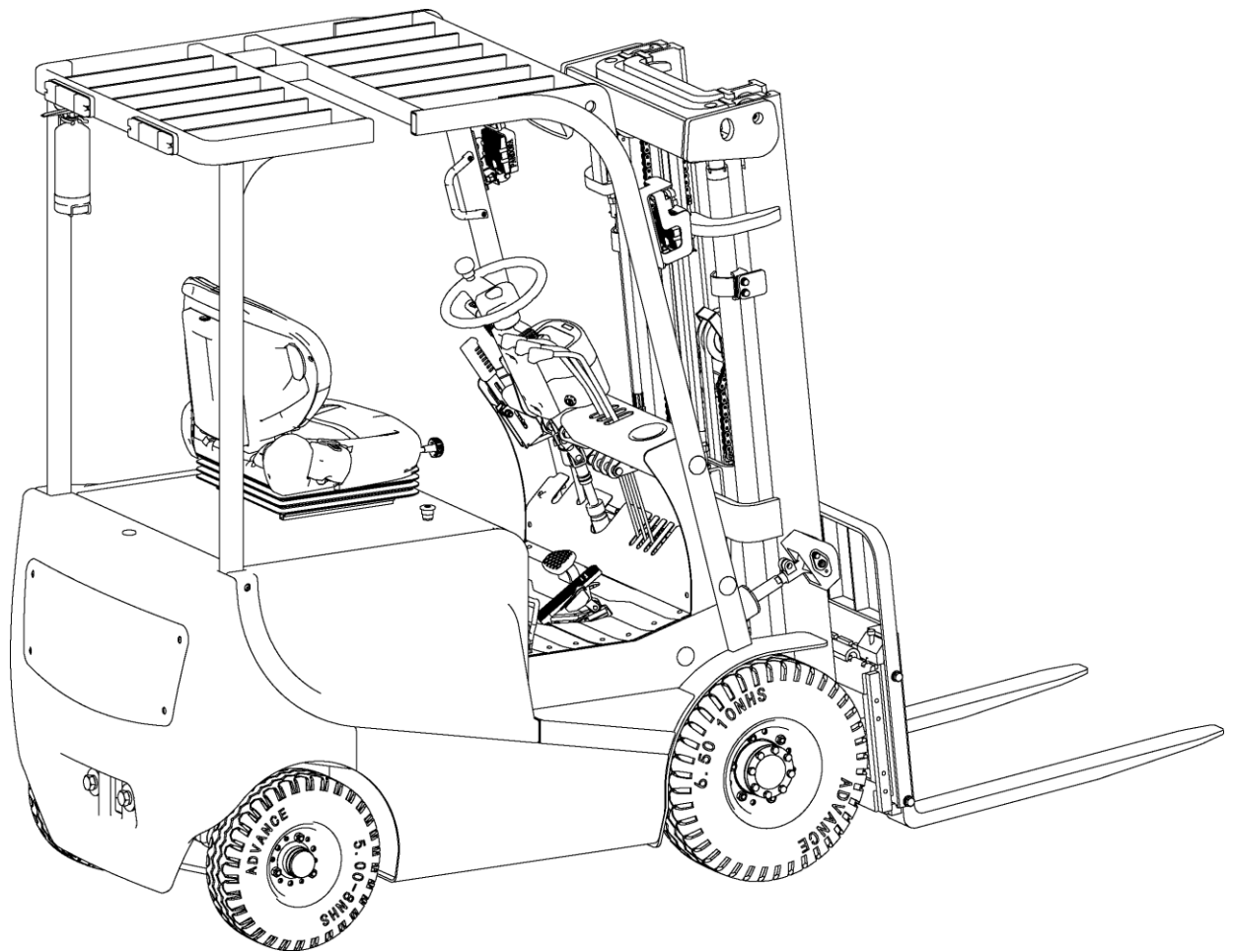

EK20R(EK20RL) type 4 wheel Counterbalanced Electric Forklift adapts battery as the power source ,uses the AC motor as the power to drive the device through the gear transmission. The lifting and tilting of the fork are driven by the DC motor and Hydraulic drive to push the cylinder to lift the cargo. Because the device is using Power to travelling & lift ,Forward & back tilting and side shift. therefor it is Low effort, High efficiency, Stable cargo operation. Simple operation, Safe and reliable .Low noise & No pollution

The biggest advantage for 4wheel counterbalanced electric forklift is that it is adopt optimized design ,wide-view mast, the mast and rubber tube pulley block are more compact .It is not easy to block the operator's sight. The size of the fork frame is increased, and the field of view is wide .Large arc roof guard ,The best angle of the grid to increase the driver's upper view .The right-hand control handle fully reflects ergonomics ,Improves the comfort of handling and reduces the labor intensity of the operator .

The device is suitable for Stacking & Handling cargo on firm ,flat floors

The service environment:

- a. Altitude does not exceed 1200m;
- b. Indoor room temperature at +5°C to +40°C ;
- c. When environment temperature at +40°C,the relative humidity can't over 50%,at low temperature ,allow bigger relative humidity
- d. Firm, Flat ground .
- e. It is forbidden to use this car in corrosive environment such as flammable and explosive or acid base.

2、 Proper use

Please using the Counterbalanced electric forklift according to this specification.

The Forklift described in this manual is a self-controlled series of Counterbalanced Electric forklift. With Multi-way valve control forklift lifting ,forward backward tilting ,side shifting etc function.

Improper use can cause personal injury or machine damage. Operators or operating companies need to ensure proper using, make sure that the truck is operated only by personnel who are trained and authorized to use the truck.

The Truck needs to be used on a firm ,flat ,intact surface and suitable surface ; the truck is designed for indoor use at room temperature from +5° C to +40° C

Use under light load without using permanent barriers or pits ,It is forbidden to operate on the slope .During Operation ,The goods must be placed approximately at the center of the truck' s load center

Lifting or Carrying people is strictly prohibited ,if carried goods .The goods must fall on the lifting point .

The rated capacity is marked on the capacity label or nameplate. And the operator must pay attention to the warning signs and safety instructions

Operating lighting must be at least 50LUX

Modification

Any modification that may affect the truck rated capacity, stability, or safety operations must be approved in advance by the Truck' s original manufacturer or Its authorized Manufacturer or its successor. This includes the effects of changes such as Braking ,steering ,Visibility, and the addition of removable accessories.

After the manufacturer or its successor approves the modification or change, the capacity name plate ,Label, identification marks, operation and maintenance manual must be changed accordingly

Truck damage caused by not following Instruction will lose its warranty

3、 Introduction of the product

3.1 Model overview

This manual is a collection of EA type 1.6T counterbalanced Electric forklift
(Hereinafter referred to as Forklift)

3.2 Product Schematic diagram & Parameter

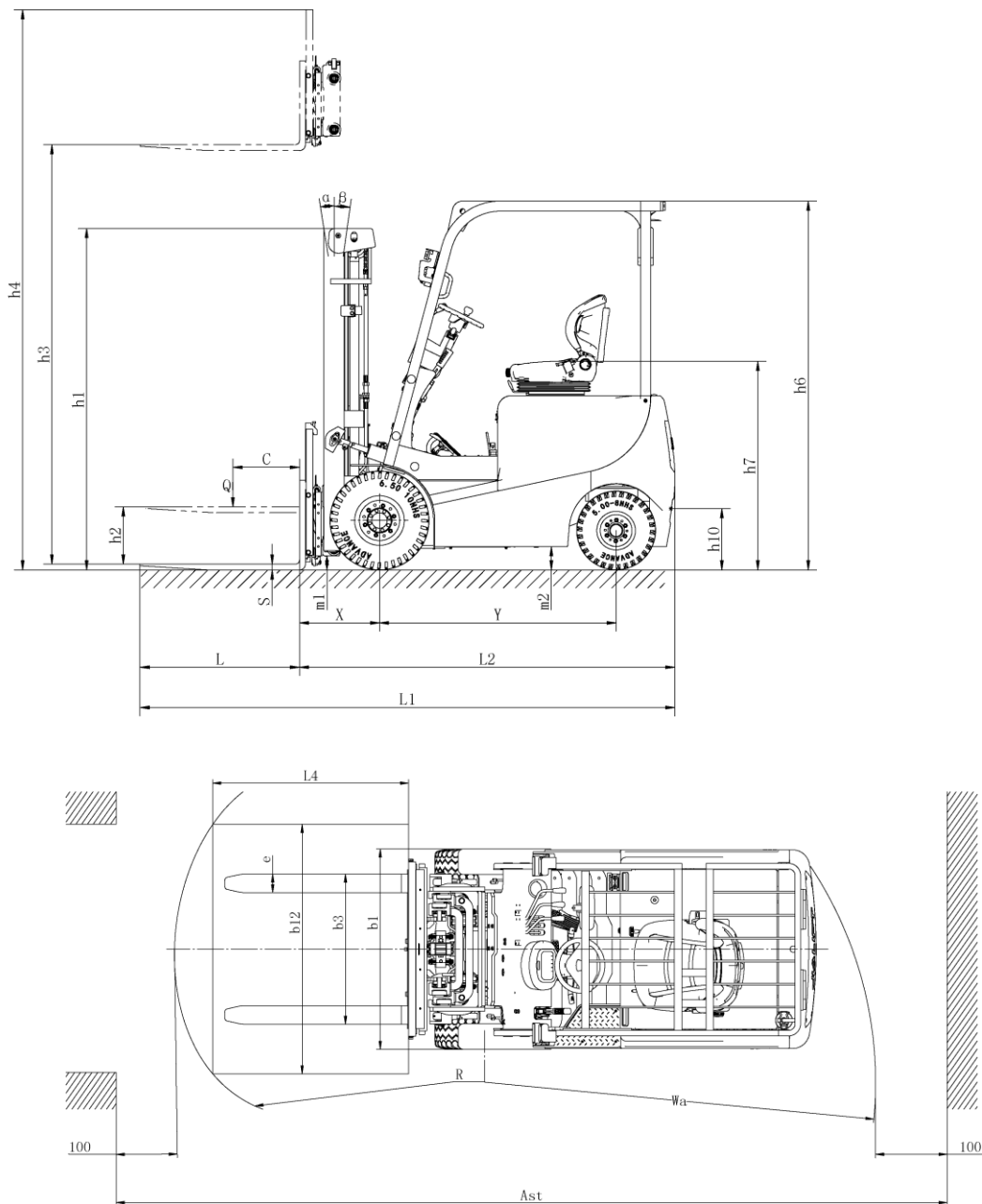

Model		EK20RL	EK20R
Power		Electric	Electric
Operator type		Rider	Rider
Load capacity	Q (lbs)	4500	4500
Lift height	h3 (in)	189	216
Load center	c (in)	20	20
Distance between fork	x(in)	18.8	18.8
Wheelbase	y (in)	55.5	55.5
Service weight(include	(lbs)	7500	8000
Tires		solid tire	solid tire
Front		6.5-10-10P	6.5-10-10PR
Rear		5.0-8-14PR	5.0-8-14PR
Wheel number, Front/Rear		2×/2	2×/2
Front wheelbase	b10 (in)	35	35
Rear wheelbase	b11 (in)	36.2	36.2
Mast tilt Forward/backward	a/b (°)	3/6	3/6
Lowered mast height	h1 (in)	84	93
Free lift height	h2 (in)	50	60
Extended mast height	h4 (in)	221	249
Over guard height	h6 (in)	86.5	86.5
Seat height	h7 (in)	47	47
Towing pin height	h10 (in)	14	14
Overall length	l1 (in)	129	129
Body length	l2 (in)	85.4	85.4
Overall width	b1/ b2 (in)	42	42
Fork size	s/e/l (in)	1.4/3.94/4	1.4/3.94/45.2
Width of fork	b3 (in)	36.2	36.2
Floor clearance under mast	m1 (in)	4.5	4.5
Ground clearance ,centre of	m2 (in)	4.9	4.9
Aisle width for pallets	Ast (in)	165	165
Aisle width for pallets	Ast (in)	169	169
Turning radius	Wa (in)	84.6	84.6
Travel speed,	(M/h)	7.5/9	7.5/9

Lifting speed Laden/unladen	(in/s)	9.9/16	9.9/16
Lowering speed	(in/s)	9.5/10.2	9.5/10.2
Max gradient performance	(%)	12/15	12/15
Service brake		Hydraulic	Hydraulic
Driving motor	(kW)	7.5	7.5
Lifting Motor	(kW)	7.7	7.7
Battery, According to DIN		no	no
Battery Voltage/Capacity	(V/Ah)	48/420	48/420
Battery weight ($\pm 5\%$)	(lbs)	1500	1500
Battery size	(in)	30/25.6/19	30/25.6/19.6
Type of drive unit		AC	AC
Sound pressure level at the	(dB(A))	70	70
Steering type		Hydraulic	Hydraulic

4、 The Schematic diagram of Operating Mechanism

The Forklift uses battery as power source ,uses electric and hydraulic to travelling ,& Lifting, Forward & backward tilting and steering Operating Mechanism diagram:

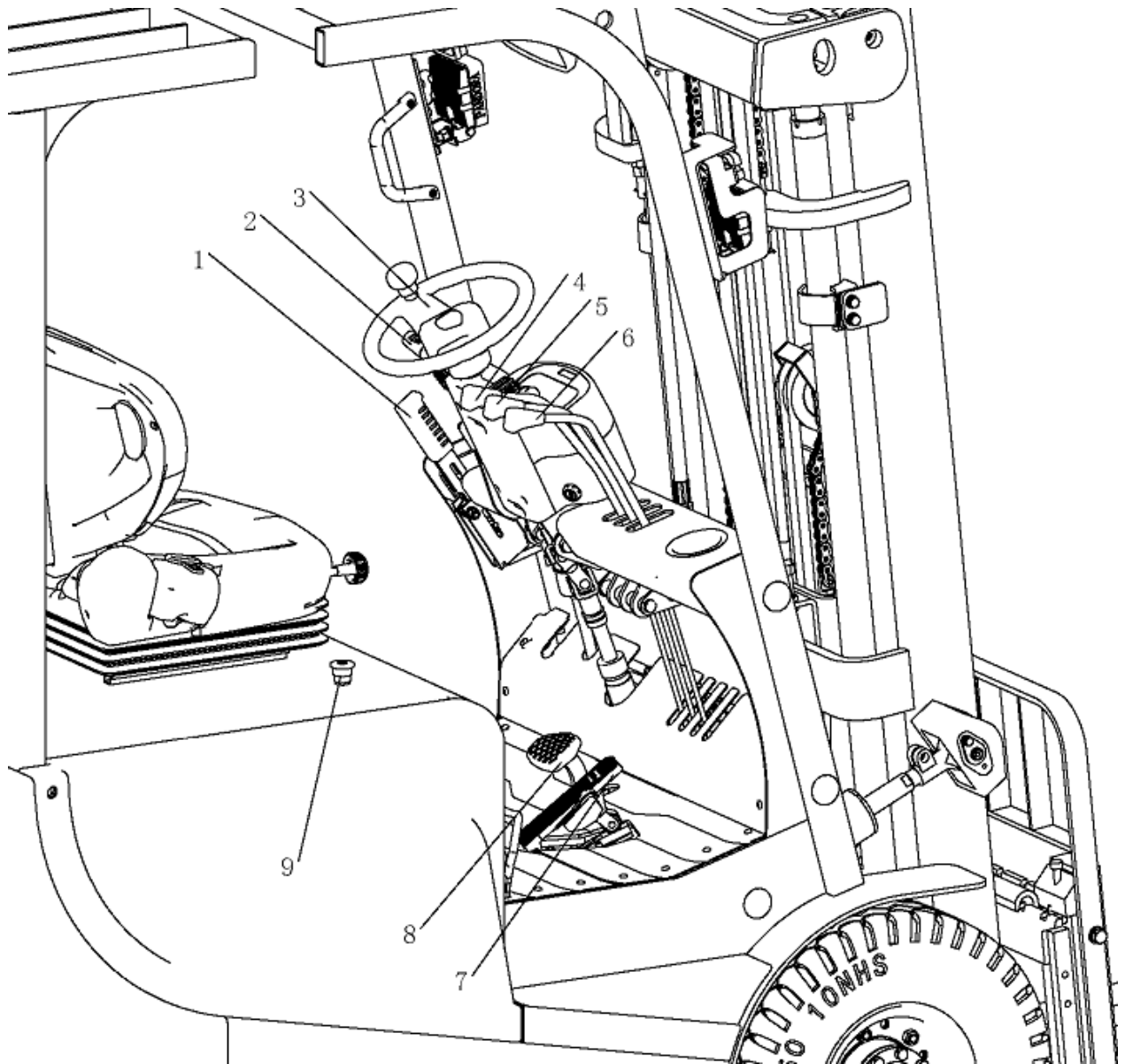

- | | | |
|--------------------------|-----------------------|-------------------|
| 1. Hand braking | 2. Combination switch | 3. Steering wheel |
| 4. Lifting handle | 5. Tilting handle | 6. Side shift |
| 7. Accelerator | 8. Foot brake | |
| 9. Emergency stop switch | | |

5、 Structure ,Principle and Adjustment of main parts of forklift

5.1 Drive system

5.1.1 Overview

The forklift is powered by battery and use a frequency conversion system to convert direct current into Alternating current by controlling the AC motor on the driving wheel . The AC motor converts the high speed and low torque to the low speed and high torque through the gear reducer ,And the driving wheel performs the action. The travel speed is controlled by frequency conversion motor speed .which is controlled by accelerator

5.1.2 Reducer casing

The reducer casing is located between the transaxle and the traveling motor. The two pairs of cylindrical helical gears reduce the rotational speed from the output shaft of the traveling motor and increase the torque transmitted from the transmission shaft .and then transmit this torque to the differential. .

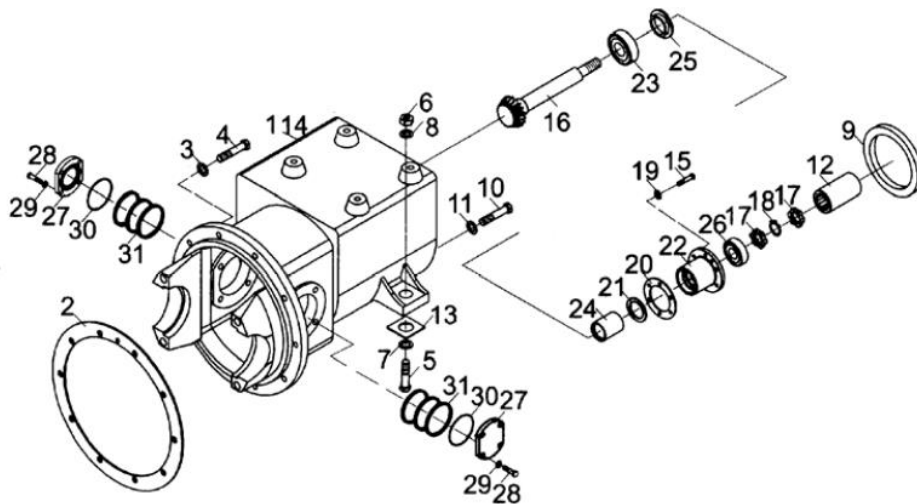

Reducer casing

- | | | | |
|------------------------|-----------------------------|------------------------------------|------------------|
| 1. Reducer casing body | 2.Washer | 3. Spring washer | 4.Bolt |
| 5.Bolt | 6.Hexagon nut | 7.Flat washer | 8. Spring washer |
| 9.Washer | 10.bolt | 11. Flat washer | |
| 12.Spline housing | 13.Adjust gasket unit | 14.Sign of mechanical transmission | |
| 15. Bolt | 16.Spiral bevel gear | | |
| 17.Round nut | 18.Tab Washer for Round nut | | |
| 19. Spring washer | 20.Gasket unit | 21. Gasket unit | 22. Bearing seat |
| 23.Bearing | 24.Bushing | 25.Oil seal | |

- | | | | |
|---------------|-------------------|---------------|-----|
| 26. Bearing | 27. Bearing cover | 28. Head bolt | 29. |
| Spring washer | 30. O-Ring | 31. Pad | |

5.2 Steering system

5.2.1 Overview

Steering system is composed of steering wheel, steering shaft, steering gear, steering pump and steering axle. The steering shaft is connected to the steering gear through the universal joint, and the connecting shaft is connected to the steering wheel through the universal joint. The steering column can be tilted back and forth to an appropriate position. And the steering axle is mounted on the tailstock at the rear of the frame. And there is a steering on the left and the right respectively. The steering cylinder is pushed by the steering cylinder piston rod through the connecting rod to deflect the steering wheel to realize steering.

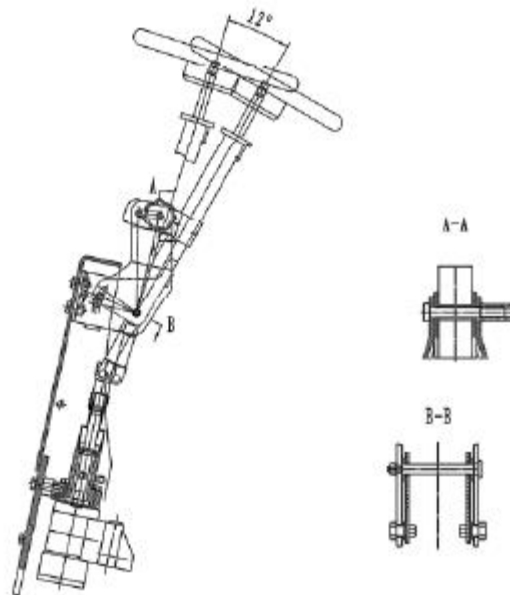

Steering device

5.2.2 Steering axle

Steering axle is a box-shaped cross-section welded structure composed of steering axle body, steering cylinder, connecting rod, steering joint and steering wheel. The steering trapezoid adopts a crank slider mechanism and the cylinder

piston rod pushes the steering joint through the connecting rod to deflect the steering wheel .then realizing steering . The steering axle is fixed to the tailstock at the rear of the frame by the front and rear pins through the fixing plate ,That is, the vibration damping pad ,So that the axle body can swing around the pin shaft .There is on joint on the left and right sides of the steering axle .and two tapered rollers on the rear hub. The bearing is mounted on the joint shaft .The wheel is fixed to the hub by the rim .And the inside bearing is provided with an oil seal to keep grease in the hub .and the steering joint cavity

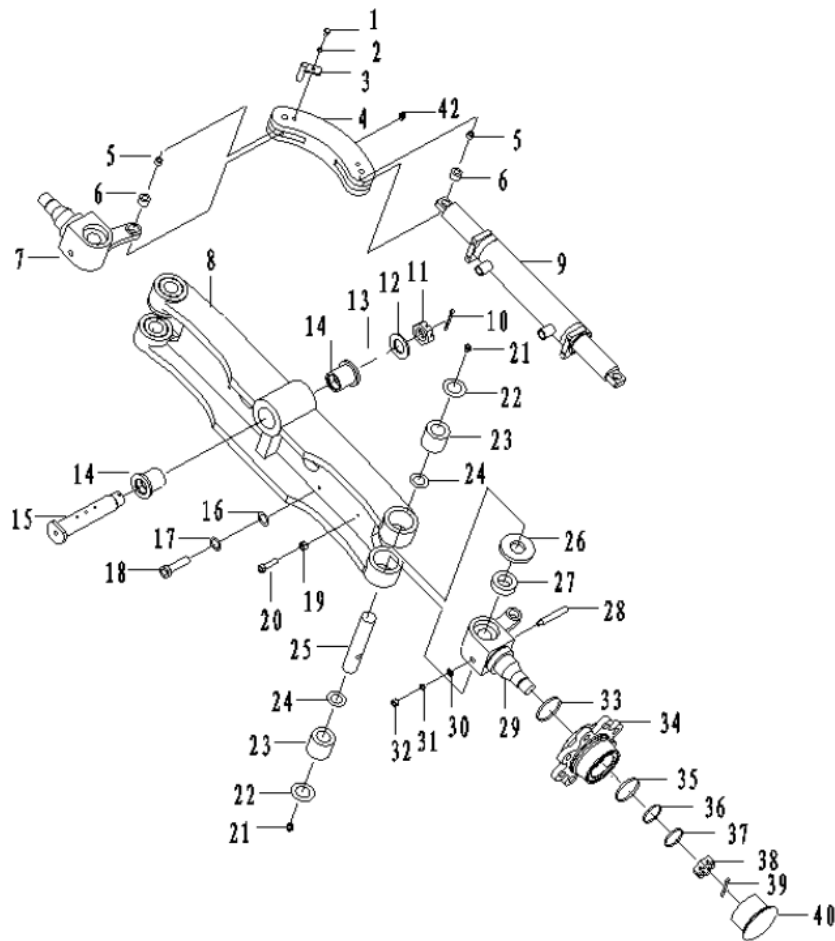

- | | | |
|----------------------|-------------------|---------------|
| 1.Bolt M16×12 | 2.Spring washer 6 | 3.tighten pin |
| 4.Connecting rod | | |
| 5.Joint bearing | 6.Bushing | 7.Left joint |
| 8.Steering axle body | | |
| 9.Steering cylinder | 10.cotter 5×50 | 11.Groove nut |
| 12.Flat washer27 | | |
| 13.Adjust Washer | 14.Bearing | 15.Pin roll |
| 16.Flat whashe12 | | |

17.Spring washe12	18.BoltM12×40	19. Nut M10×1.25
20.Bolt M10×1.25×40	21.Bent neck grease nipple M6	22.Oil seal
23.Bearing		
24. O-ring 25.8×1.8	25.Steering joint kingpin	26.steering joint adjust washer
27.Bearing	28.set pin	29.Right joint
30.Washer 8	31.O-Ring	32. Nut M8×1.25
33.Framework oil seal	34.Steering hub	35.Bearing
36Bolt M8×18	37.Flat whasher24	38. Nut M24×2
39.Cotter 5×45	40.Wheel hub cover	

5.2.3 Adjustment ,Maintenance essential

(1) As the picture shows, Grease the inner cavity of the hub, the inner and outer bearings and the hub cap, and apply some grease to the lip of the oil seal.

(2) Fixing the outer ring of the bearing to the hub and attaching the hub to the steering joint shaft .

(3)Install the flat washer and tighten the castle nut with a torque of 206-235n.m(21-24kgm),loosen the slotted nut and then screw the nut back, the torque is 9.8n.m(1kgm)

(4) Gently tap the hub with a wooden hammer and turn the hub 3-4 turns to ensure that the hub is not loose.

(5)Tighten the Castle nut so that the slot is aligned with the opening pin hole on the Knuckle

(6) Then Tap the hub with a wooden hammer and turn hub 3-4 turns by hands to ensure smooth rotation and measure the torque of the hub, the value is 2.94-7.8N.m(0.3-0.8kgm)

(7) When the turning torque is higher than the specified value ,It can be retracted 1/6 turn, and then measure its rotational torque

(8) When reach the specified torque .Then lock the slot nut with a split pin .

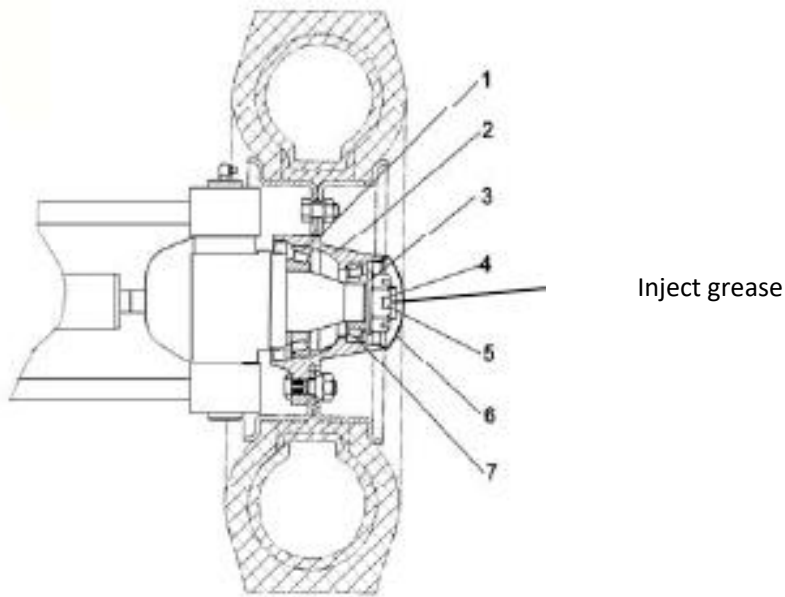

Preload adjustment

5.2.4 Check after reinstallation of steering system

(1) Turn the steering wheel from side to side and see whether the forces are even, and the rotation is steady .

(2) Check whether the oil pressure pipe is arranged correctly, and whether the left and right steering is installed in reverse .

(3) Lift the rear wheel .slowly turn the steering wheel left and right .and repeat it several times to remove the air from the hydraulic lines and cylinders .

5.3 Braking system and schematic diagram.

5.3.1 overview

The brake mode of the forklift consists of two type: service brake and parking brake .

The service brake refers to the braking method used by the forklift during the operation, Brake with foot brakes

When the brake cylinder pumps the brake drum to the same force as the main brake shoe and the auxiliary brake shoe until the upper end of the brake

shoe is pressed against the fixed pin ,the brake shoe moves in the direction of the brake drum. After the fixed pin is pressed ,the frictional force between the friction lining and the brake drum is increased. Because the main brake shoe gives the auxiliary brake shoe a much greater pressure than the brake cylinder pressure ,thereby generating a large braking force .

The parking brake is mainly used in the parking state to prevent accidents caused by slopes. A parking switch is mounted on the parking brake .and the control circuit is disconnected in the parking the stop brake must be released before the forklift starts to walk ,and the control circuit can be connected .Parking brake has the function of adjusting tightness .

5.3.2 Brake pedal

The brake pedal portion is constructed as shown in the figure ,and the pedal converts in the pedaling force acting on the pedal into the brake oil pressure by the push rod of the master cylinder .

1. Brake oil cup
- 2.Brake pedal
- 3.Brake master Cylinder
- 4.brake support
- 5.limit bolt
- 6.brake sensor

5.3.3 Brake master cylinder

The master cylinder includes a valve seat ,a check valve, a return spring ,and a main cup, piston and auxiliary cup. The master cylinder piston is actuated by the operating brake pedal through the push rod, when the brake pedal is depressed ,the push rod pushes the piston forward .and the brake fluid in the pump body flows back to the oil storage tank through the oil return port until the main the cup stops the oil return hole .After the main cup is pushed over the oil return port .The brake fluid in the front chamber of the main pump is compressed and the check valve is opened to flow through the brake line to the sub -Pump.in this way ,each of the sub-pump pistons protrudes outward ,so that the brake shoe friction plate and the brake drum are in the contact with each other to achieve the effect of deceleration of braking .At this time ,The rear chamber of the piston is replenished by the brake fluid from the oil return port and the oil inlet port .When the brake pedal is released ,the piston is pressed back by the return spring and the brake fluid in each brake cylinder is also compressed by the brake shoe return spring .so that the brake fluid returns to the original position. The brake fluid in the master cylinder flows back to the oil storage tank through the oil return port .The pressure of the check valve is adjusted to a certain ratio with the residual pressure in the brake line and the

brake cylinder .So that the cylinder of the pump is properly placed to prevent oil leakage and eliminate the possible air resistance during emergency braking .

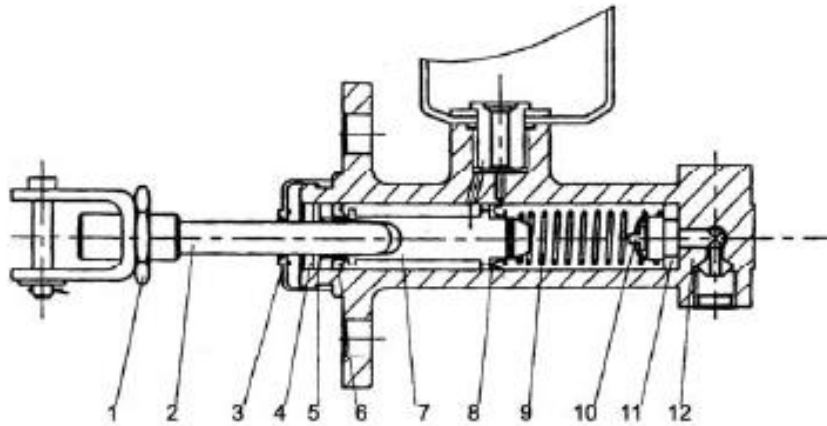

- | | | | |
|---------------------|----------------|------------------|-----|
| 1. Lock nut | 2. Push Rod | 3. Dust cover | 4. |
| Locking wire piston | 5. Lock washer | 6. Auxiliary cup | 7. |
| Check valve | 8. Master cup | 9. Spring | 10. |
| | 11. Valve seat | 12. Pump body | |

5.3.4 Brake

The brakes are double-hoof brakes mounted on both sides of the transaxle. The brake consists of 2 sets brake shoes, brake cylinder and regulator . One end of the brake shoe is in contact with the fixing pin .and the other end is in contact with the adjusting device .Press the brake stop by the return spring and the compression spring lever .In addition .the brake is equipped with stop brake mechanism and automatic adjustment device .

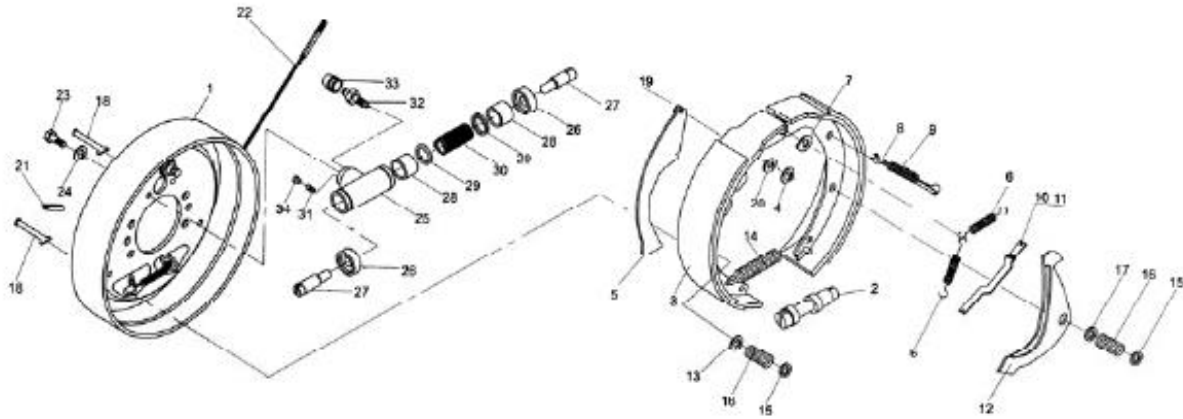

- | | | |
|--|--------------------------------|-----------------------------------|
| 1. Brake baseplate assembly | 2. Slack adjuster | 3. Friction disc |
| 4. Elastic gasket wire | 5. Hand brake lever | 6. Return Spring |
| 7. Washer | 8. Pole | 9. Return Spring |
| 10. Hand push Rod | 11. Compressed spring | 12. Adjustment Lever |
| 13. Pressure spring seat | 14. Spring | 15. Pressure spring Cover |
| 16. Spring | 17. Pressure spring seat | 18. Pressure spring Lever |
| 19. Support pin | 20. Washer | 21. Rubber plug |
| 22. Brake cable assembly | 23. Bolt M8×16 | 24. Spring Washer 8 |
| 25. Brake cylinder pump piston top rod | 26. Brake pump guard | 27. Brake pump piston |
| 28. Piston | 29. Cylinder Cup | 30. Brake pump spring |
| 31. Brake oil plug | 32. Brake cylinder Bleed screw | 33. screw protector for pump vent |
| 34. Dust cover | | |

5.3.5 Parking brake operating device

The parking brake handle is cam type. And the brake can be adjusted by the adjuster at the end of the brake handle.

Braking force adjustment :turn the adjuster clockwise to increase the braking force ,turn the adjuster counterclockwise to reduce the braking force, pulling force:200 N~300N

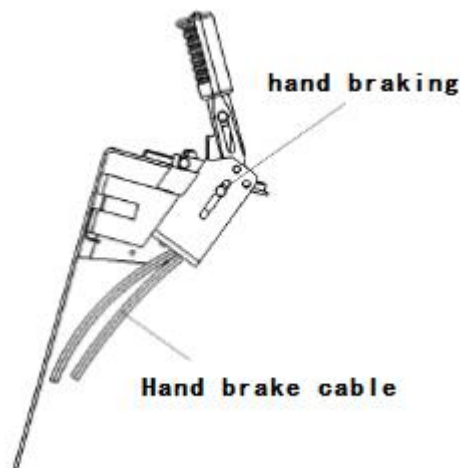

aring brake handle

5.3.6 Brake assembly and adjustment essentials

Decomposition, assembly ,adjustment of the brake and adjustment of the brake pedal in the disassembled state of the wheel and the hub

1、 Decomposition of the brake

(1) Remove the support pin ,adjustment lever ,adjustment device and spring on the auxiliary brake shoe. As figure 1

(2) Remove the shoe return spring ,as figure 2

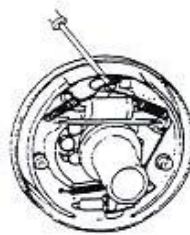
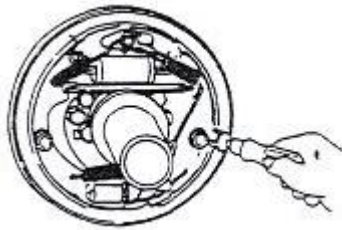

Figure 1

Figure 2

(3) Remove the anchor spring on the

main brake shoe, as figure 3

(4) Remove the main brake shoe and the auxiliary brake shoe, Remove the adjuster and adjuster spring at the same time ,as figure 4

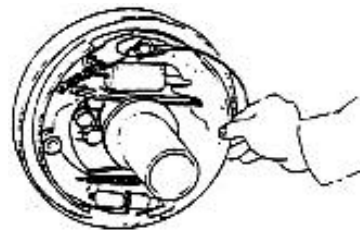
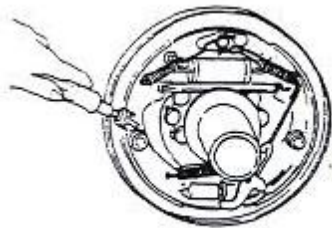

Figure 3

Figure 4

(5) Remove the brake pipe from the brake cylinder ,then remove the mounting bolts of the brake cylinder and remove the brake cylinder from the brake base.as figure 5

(6) Remove the E-shaped retaining ring for the brake cable on the brake base plate ,then remove the bolts that mount the brake base plate and remove the brake base plate from the drive axle .as figure 6

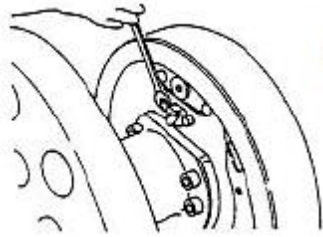

Figure 5

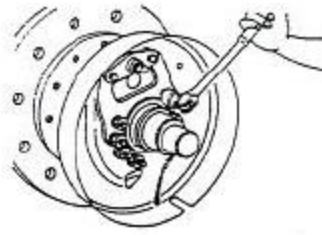

Figure 6

(7) Decompose the brake cylinder:remove the dust ring,press the piston out of the piston on the other side and press the piston with your fingers .as figure 7

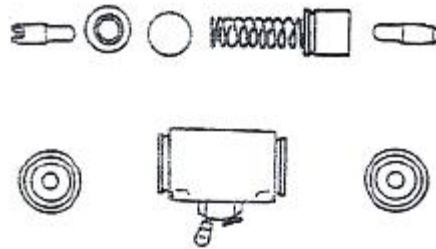
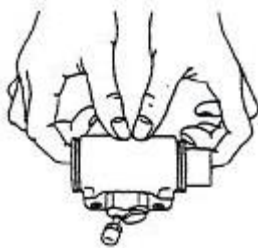

Figure 7

2、 Brake assembly

(1) Apply brake fluid to the cup and piston of the brake cylinder and assembly the spring ,piston cup. Piston and guard ring in order

(2) Install the brake cylinder on the brake floor.

(3) Install the brake base plate on the drive axle

(4) Apply heat-resistant grease to each side as shown in figure 8,Be careful not to apply it to the insert

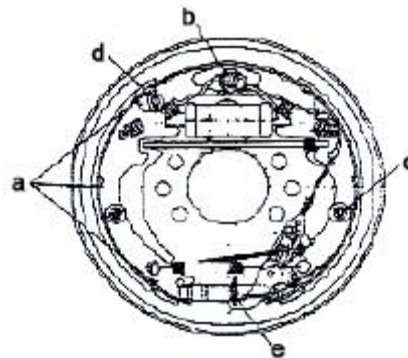

(a) Base plate and brake shoe contact surface ;

(b) Fixed pin;

(c) Contact surface of the shoe and the spring seat ;

(d) Hand brake lever support pin;

Figure 8

- (e) Adjusting mechanism threads and other rotating part .
- (5) Parking brake cable is stuck with E-shaped retaining ring .
- (6) Install the brake shoe with a fixed spring ,as figure 9
- (7) Attached the compression spring to the hand brake lever and attached

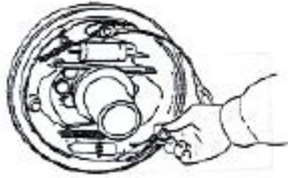

Figure 9

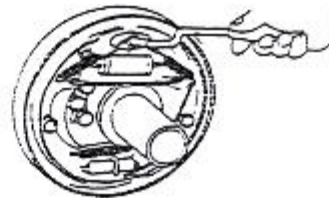

Figure 10

(8) Install brake shoe guide to support pin and then install brake shoe return spring, Install the main hoof first, and then the auxiliary hoof, As shown in figure 11

(9) Install adjuster, adjuster spring, ejector pin, ejector return spring ,pls pay attention to following point

- (a) Adjuster thread direction and its installation direction .
- (b) The spring direction of the adjuster (the tooth part of the adjuster is not allowed to contact with the spring
- (c) The direction of the ejector return spring (the spring hook of the supporting pin shall be fixed on the opposite side of the ejector)
- (d) the lower end of the adjustment lever must be in contact with the adjuster tooth

(10) Connect the brake tubing to the sub pump

(11) Measure the inner diameter of the brake drum ,the out diameter of the brake shoe ,and adjust the adjuster to make sure the difference between the inner diameter of brake drum and the outer diameter of friction plate of the brake shoe is 0.0in -0.02in,as figure 12 shows .

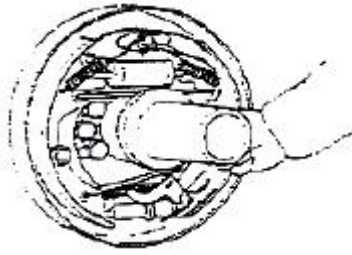

Figure 11

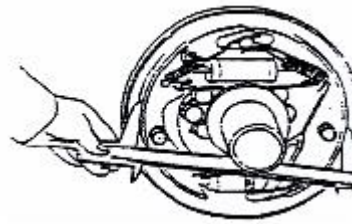

Figure 12

3、 The operation test of automatic gap adjuster shown as in Figure 13

(1) First ,the diameter of the brake shoe is close to the specified installation size ,and the adjuster is rotated by the hand to adjust the lever, when the hand is released ,the adjustment lever returns to its original position ,and the adjuster gear does not rotate

Note: even when the hand is released ,the adjuster gear returns with the adjustment lever and the adjuster still works

(2) If the adjuster cannot perform the above actions when pulling the adjustment lever ,the following checks shall be made :

(a) Fix the adjustment lever ,the ejector pin, the ejector spring and the compression spring seat

(b) Check the ejector return spring and the adjuster spring for damage and check the rotation of the adjuster gear and its meshing parts of excessive wear or damage, check if the lever is in contact with the gear ,replace damage part .

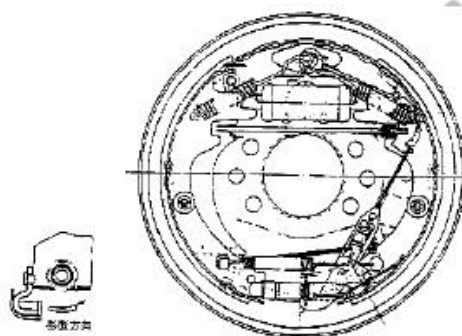

Figure 13

5.3.7 Brake pedal adjustment .shown as figure 14

(1) Shorten the putter

(2) Adjust pedal limit bolt .Shown as figure 15,adjust the pedal height

(3)Adjust the push rod until the front end of the push rod contacts the master cylinder piston. And then retract 1-2 turns to ensure that the free travel of the pe

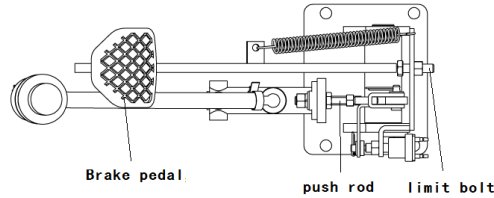

Figure 14

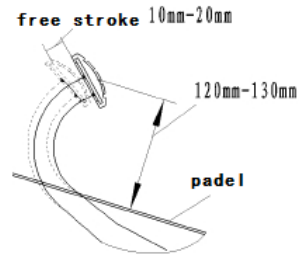

figure 15

(4) Lock the push rod nut and the pedal limit bolt nut

(5) Brake switch adjustment as shown in figure

16

(a) When the height of brake pedal is adjusted ,release the lock nut of brake switch

(b) Remove the plug to separate the wires

(c) Turn the switch to make clearance $A=0.04in$;

(d) Make sure the brake light is on when the brake pedal is pressed

(e) Finally lock the nut

brake switch

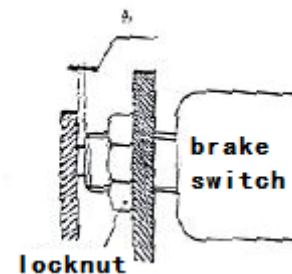

figure 16

5.3.8 Repair & Maintenance

① Before the running test ,the new drive axle needs to be filled with gear oil(the selection of gear oil should be strictly in accordance with manual Specification ,for the specific model ,please refer to table 2-1.When refueling ,it should be injected from the oil filling hole in the upper part of the axle housing until the oil level in the middle of the axle housing sees oil over flow

② the thickness of the friction plate on the brake shoe is0.3in。 The minimum thickness allowed is0.078in。 These two parts are the key parts of the braking system ,which should be checked once a month .if excessive wear is found ,it should be replaced in time to avoid accidents .

③ Every 50h technical maintenance:

I 、 After the new bridge has been working with the main engine for 50h,the gear oil should be replaced .When changing oil ,lean the bridge and add new oil

II 、 Check the fastening of each fastener and find that it is loose and tightened immediately

III、 Check for oil leakage at the joint between the wheel axle and the hub .If there is leakage, Reapply the sealant

④ Monthly technical maintenance

I 、 Check the brake drum for wear and tear with or without destructive wear

II 、 Check the brake shoe wear and replace it when the wear has not meet the requirements

III、 Check if the oil level of the axle housing meets the requirements. If the oil level is lowered ,it should be replenished in time

⑤ Technical maintenance every six months :replace the gear oil in the bridge every six months

⑥ Annual technical maintenance: disintegrating inspection shall be carried out in the working year

⑦ Requirements for checking and commissioning of the projects during installation

When the wheel hub of drive axle is reinstalled ,should pay attention to adjusting the brake clearance adjuster.so that the clearance between brake drum and friction disc is between 0.01in and 0.02in ,the taper roller bearing on the hub shall be filled with about 100ML #3 lithium grease

Adjusting the clearance of the wheel hub bearing tighten the inner nut until the hub brake drum can only barely rotate. Then turn the locking inner nut back 1/8 turn ,at this time ,the hub brake drum should be about the rotate freely, without jamming ,and there is no obvious axial clearance and yaw phenomenon, then the lock washer is assembled, and the outer nut is used for locking

5.4 Operating system

The main working mechanism of the forklift is the fork, Which relies on the fork to load, unload, stack and transport the pallet or cargo .

The fork is mounted on the carriage ,and the carriage moves up and down in the mast by chain drive or the overall movement of the mast ,so that the goods are off the ground or stacked on the shelf .the overall movement of the chain drive and the inner mast achieved by the expansion and contraction of the cylinder, the forklift operating process is realized by controlling the expansion and contraction of the working cylinder(including the tilting action)

The expansion and contraction of the cylinder is achieved by the control of a manual valve stem, which is supplied with pressurized oil.

A safety valve is installed in the circuit of the lifting cylinder to slow down the speed during the mast lowered, and the safety drop effect is achieved.

5.5 Electrical system

5.5.1 Overview

The electrical system mainly includes battery pack, traction motor, pump motor, traction motor controller and pump motor controller, steering combination switch, multi-way valve block controller, display instrument, combined control switch, instrument and lighting deviceless

5.5.2 Combination meter

The new combination meter is used to realize the auxiliary control function and provide the driver forklift condition display interface. It consists of a control circuit, a cumulative time counter (liquid crystal display), a battery fuel gauge, a fault code display, and other display circuits. According to the current demand situation of electric forklift, this instrument has made a new design in the control circuit and display form, which can provide drivers with intuitive truck status information, compact structure, elegant appearance, high automation and reliable quality.

Smart Display The display has six built-in red LCD displays, which give the operator some easy information about the health of the forklift. As shown below picture

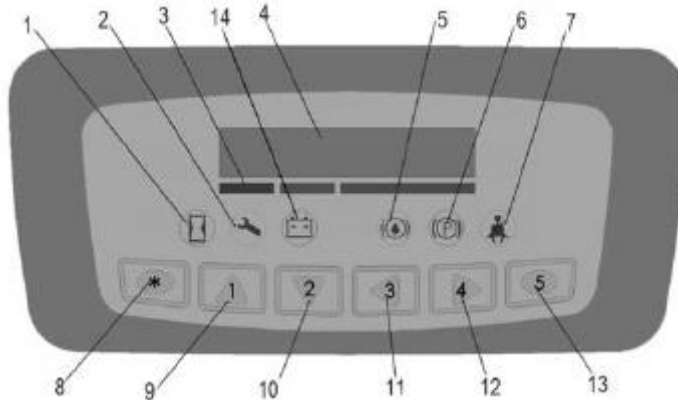

- | | | |
|--|--|---------------------------|
| 1.Waiting time lamp | 2.Trouble alarm lamp | 3.battery mark |
| 4.Speed ,power ,time display | 5.Temperature alarm lamp | |
| 6.Hand brake light | 7.Seat lamp | 8.Instrument function key |
| 9.Function selection key (UP) | 10Function selection key (Down) | |
| 11.Parameter adjustment button (small) | 12.Parameter adjustment button (large) | |
| 13.Exit function key | 14Battery indicator | |

1) Battery

The battery indicator lights up—the measured battery level is less than or equal to 10% of the normal battery charge.

2) Wrench

The fault indicator flashes—the Forklift is in an alarm state.

3) Temperature

The temperature indicator flashes—the forklift is in an alarm condition due to high IMS temperatures

4) Seat

The seat light flashes - the operator has left the seat.

5) Handbrake

Handbrake light flashes - hand brake function is enabled .When the main switch is closed, the Eco Smart display will be fully tested, and all LCD will be closed in sequence.

5.6 Hydraulic system

The oil pump motor drives the gear pump to provide hydraulic power. The two lift cylinders are responsible for the lifting and lowering of the forks. The two tilting cylinders complete the front and rear tilting movement of the mast, and one side shifting cylinder completes the left and right side shifting of the pallet rack. The control of the lifting, tilting and side-shifting oil circuits is controlled by three handles on the triple valve. The lifting action is controlled by a single-acting oil circuit on the triple valve, and the tilting and side movement are controlled by the double-acting oil path on the triple valve. The hydraulic system pressure of this model can only be adjusted on the triple valve. It has been debugged before leaving the factory. After the factory, it is strictly forbidden to adjust the self-sales personnel or professional maintenance personnel to avoid safety accidents.

Multi-way valve outline drawing

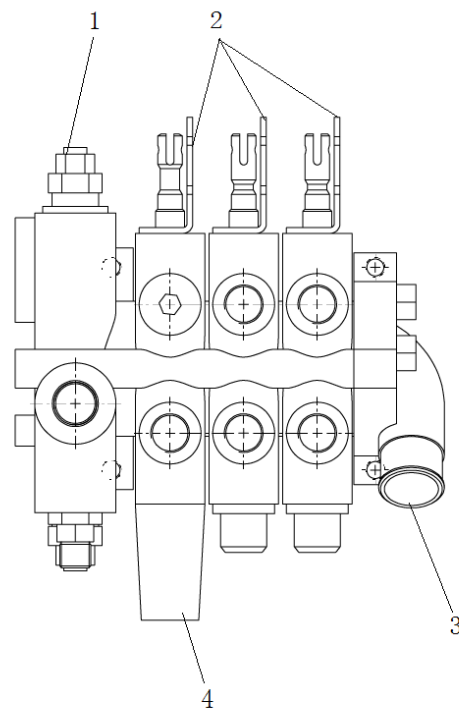

- 1、 Safety valve 2、 Micro switch bracket 3、 Return port 4、
Lifting speed sensor

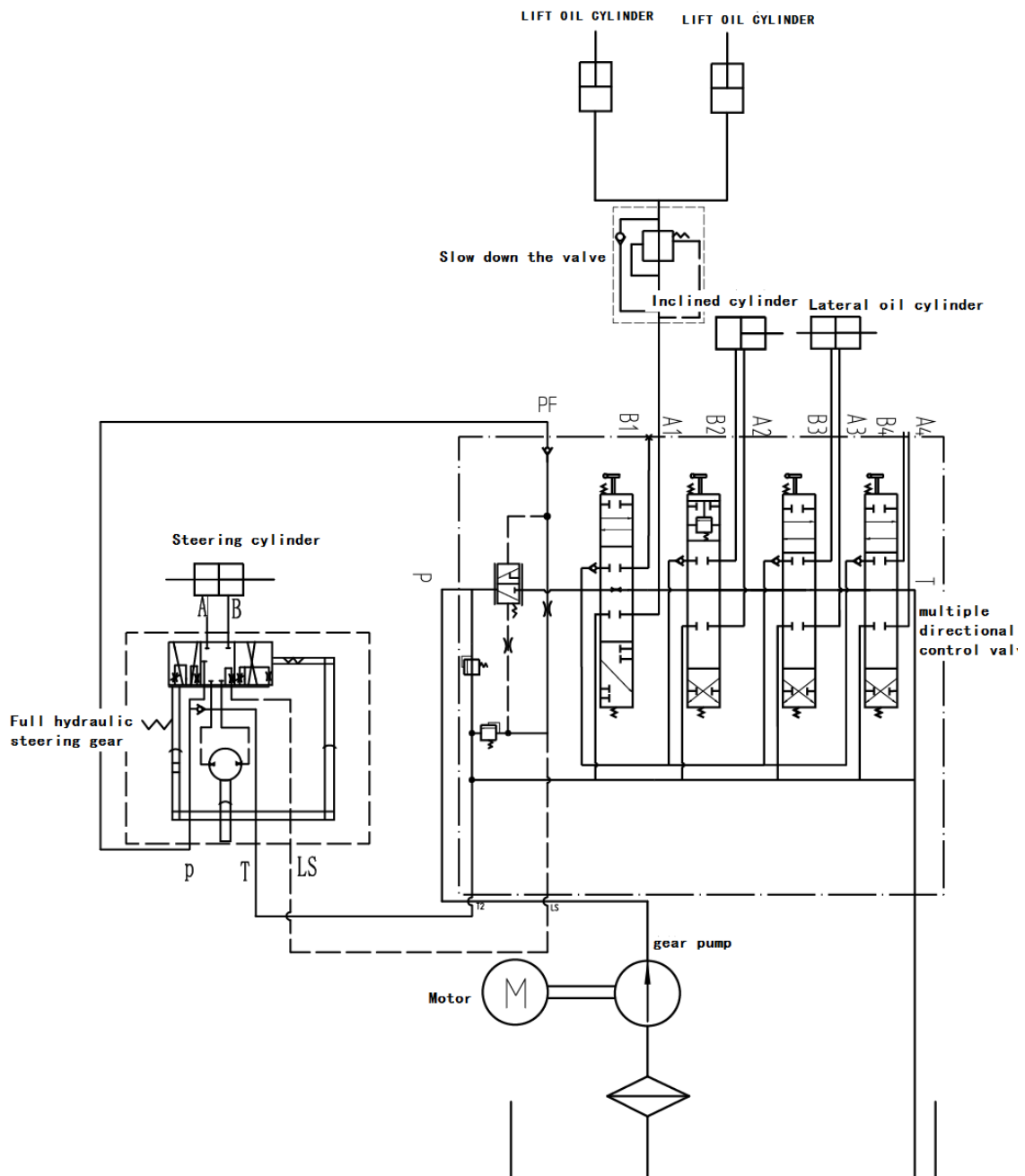

7、Hydraulic schematic

8、 Operating Specification

Before operating the forklift, please be familiar with the dashboard function of each switch/button.

8.1 Start ,Run Parking

① Insert the key into the key switch, turn to the right, and turn the emergency power off safety switch in the direction indicated by the arrow above the button. The control circuit opens.

② The fork rises from the ground about 10 cm。

③ Begin to loosen parking system.

④ According to the requirements in the direction of the forward or backward direction of switches

⑤ On the accelerating pedal slowly, until the required speed.

⑥ In the process of operation, forklift exception occurs fault, need to quickly cut off power supply, please press the red emergency power switch.

⑦ When the forklift is turning, you should reduce the speed and, if possible, try not to make sharp turns.。

⑧ Forklift truck carrying gradeability is 15%, so the uphill slope needs to understand the situation, when climbing the forklift must accelerator pedal pressed down as far as possible, the maximum climbing force can be achieved

⑨ When the forklift is downhill, release the accelerator pedal, please press the brake pedal at the same time to ensure safety.。

⑩ When the truck stops driving, the right foot leaves the accelerator pedal and the forklift pedal is pressed until the truck stops completely. Put the fork to

the lowest position, tighten the parking brake handle, press the safety switch, and pull out the key. (Note that you cannot leave the truck without tightening the hand brake lever).

8.2 The steering wheel Angle adjustment

According to the individual operating habits, steering wheel angle can be adjusted . Adjustment method is as follows: Loosen the left hand of direction column, adjust the steering wheel to the right position, then lock regulating handle.

8.3 Accelerator pedal operation

Determine the vehicle forward or backward. Toggle joystick in place, right foot will tread the foot pedal accelerator to make the forklift slowly forward or backward. Continue down the pedal, the forklift 's speed to speed up.

Started never put foot accelerator jammed on to the end, to avoid the vehicle out of control.

8.4 Brake pedal operation

When the moving forklift needs to stop, release the pedal accelerator, move the right foot to the middle of the foot brake pedal, and the vehicle will stop after braking



8.5The using of emergency power safety switch

If the forklift is out of control during driving, or if it is smoked or burnt during use, please press the emergency switch on the forklift seat cover and the power will be cut off. Find out the cause and clear the fault before you can open it. The method of opening is as follows: the emergency power-off safety switch is rotated in the direction indicated by the arrow above the button, and the opening is completed.

The button of the emergency power off switch is a plastic piece. When pressing down or rotating up, do not use excessive force to avoid damage to the switch.

8.6 The use of speakers and reversing speakers

For the safety of driving, vehicle equipped with speakers and reversing speakers. To remind others when driving, press the horn button in the middle of the steering wheel, when forklift is reversing, reversing the horn alarm sound will start automatically alert pedestrians.

8.7 The operation of the hydraulic control rod

Hydraulic control rod is for hydraulic transmission parts distributor of different needs, there are two files, joystick is divided into the following functions:

(1) forklift lever: a. fork lift (back pull); b. Fork stay ; c. Fork lowered (push forward)

(2) Tilt lever: A. back tilt (back pull); B. stay in place; C. Forward tilt (push forward)

Every joystick can only Operate one hydraulic circuit. When the lever is moved, the attached micro switch will start the oil pump motor to rotate at the same time and output the hydraulic oil with pressure to make the relevant hydraulic components move. To ensure the safety of hydraulic system ,pressure overflow device is installed on the hydraulic valve block. Once the pressure exceeds the set standard .The control valve block will automatically discharge pressure overflow.

Note: The pressure device on the hydraulic valve block must not be adjusted at will!

8.8 Battery capacity indicator

The dashboard for forklift battery capacity has capacity display function, can also use electricity time statistics (cumulative hour).

8.9 Handling stacking operation

(1) How to carry heavy objects on the pile of goods

Slowly drive the forklift to the item to be transported, make the fork parallel to the ground, lift the fork to the height where it can be inserted, move the fork

and slowly move forward, when the fork is fully inserted then parking and stepping on the brakes, operate the lifting handle to raise the weight to a certain height, tilt the mast backwards, slowly reverse the forklift, do not touch the adjacent goods, Lowered the goods to a correct position when the heavy objects completely leave the cargo pile. and then carry it by walking.

(2) Putting heavy objects on the pile of goods

The weight is at a low position, the mast is tilted backward, and the stack is decelerated as it travels close to the cargo pile. When it is determined that the forklift is in line with the stacking goods, the brake is stepped on the brake to slowly adjust the inclination of the mast to a vertical state, lifting the goods slightly exceeds the height of the pile, and then the forklift slowly travels forward to stop above the pile. Slowly push and lower the control lever. Once the heavy objects handled by the stack are dragged, lower the fork to the hollow position. When the fork is pulled out from the heavy object, ensure that the retracted position is unobstructed before it can be reversed. After the fork has completely left the heavy object, lower the fork and the mast is tilted backwards before carrying out a round of handling operations.

9. Maintenance and Service Manual

The part on the forklift, especially the safety devices, shall not be modified without permission, and the speed of the forklift must not be changed. All spare parts supplied by the original manufacturer are subject to strict quality inspection. In order to ensure the safety and reliability of the forklift, please use the original accessories. Replacement parts, including all oils, must be collected and disposed of in accordance with local environmental and health laws and regulations.

9.1 Repair and maintenance of safety procedures

Maintenance technician: The maintenance and service should only be performed by special personnel trained by the manufacturer. After the technician sent by after-sales department of the manufacturer completed maintenance and servicing work, they should sign on the service log.

Lifting of the forklift: When a forklift needs to be lifted for maintenance, the lifting device must be safe and reliable and strictly attached to the lifting

point. When the forklift is lifted, appropriate measures must be taken to prevent the forklift from slipping or tipping over (wedges, blocks can be used).

Cleaning Operation: Flammable liquid can not be used for cleaning the forklift. Before cleaning, take safety precautions to prevent electric sparks (e.g. sparks caused by short circuit). When operating the accumulator, connectors on it must be disconnected. Use soft air suction or compressed air, non-conductive and anti-static brushes to clean electric and electronic components.

If the forklift is cleaned with a water spray or a high-pressure cleaner, all electrical and electronic components must be carefully pre-covered, because the humidity can cause malfunctions. Do not use steam nozzles for cleaning.

Operation of Electric System: Operation on the electric system should only be performed by specially trained personnel. Before performing any operation on the electric system, precautions must be made to prevent electric shock. When operating the accumulator, connectors on it must be disconnected.

Welding operations: To prevent damage to electrical or electronic components, these electrical components must be removed from the vehicle before any welding operations are taken.

Installation: When repairing or replacing hydraulic components, electric and electronic components, make sure to install them back to their original positions.

Wheels: Quality of the wheels has significant effect on stability and driving performance of the forklift. Modification on wheels can be performed only with the approval from the manufacturer. When replacing wheels, ensure that the forklift is leveled as delivery state (wheels must be replaced in pairs, i.e. replace right wheel together with left one).

Lifting chain and rollers: Chain and rollers will be worn quickly without good lubrication. Perform periodic lubrication according to following maintenance table. Shorten the lubrication period under adverse operation conditions (such as in dusty and hot environment).

Hydraulic oil pipe: The oil pipe must be changed every 6 years. When change the hydraulic assembled parts, the oil pipe should be also changed.

9.2 Routine Maintenance

9.2.1 Check the liquid level of electrolyte in the accumulator.

The liquid level will be higher when being recharged.

9.2.2 Check every pole, every cable and their covers.

9.2.3 Check if the accumulator box is secured.

9.2.4 Check the forklift for oil leakage.

9.2.5 Check the chain, rollers, fork, oil pipes and horn.

9.2.6 Check the brake.

9.2.7 Check the wear and tear of drive wheels and loading wheels.

9.3 Professional maintenance manual

It is very important for safe operation of the forklift to perform overall professional maintenance. Failure in performing maintenance according to specified interval may cause malfunction of the forklift, and potential risk to human and equipment.

Maintenance periods listed in this manual apply to single shift a day under normal operation conditions. If using in dusty environment, the ambient temperature varies remarkably or in multi-shift situation, the maintenance period has to be shortened.

Maintain the forklift according to following maintenance list. Maintenance periods are as follows:

W = Every 50 work hours, but at least once a week.

A = Every 250 work hours, but at least once every 3 months

B = Every 500 work hours, but at least once every 6 months

C = Every 2000 work hours, but at least once every 12 months

Additional operations should be performed in trial run period:

(In initial 50 – 100 working hours or after two months)

— Check the nuts on the wheels, and tighten them if necessary.

— Check the hydraulic components for leakage, and tighten them if

necessary.

—Replace the hydraulic filter

			Time interval of maintenance●			
			W	A	B	C
Brake	1.1	Check the air gap of the electromagnetic brake			●	
Electrical system	2.1	Check the operation switch to show the function of the device and components	●			
	2.2	Check alarm system and safety device		●		
	2.3	Check the cable for damage and the terminal is secure			●	
	2.4	Check the function of the micro switch setting	●			
	2.5	Check controller and EPS controller			●	
	2.6	Cable and motor fixing			●	
Power supply	3.1	By observing the battery		●		
	3.2	Visual inspection battery charging plug			●	
	3.3	Check if the connection of the battery cable is tight, and if necessary, apply grease to the electrode.			●	
Driving system	4.1	Check the gearbox for abnormal noise			●	
	4.2	Check the running mechanism and grease, check the reset function of the operating handle		●		
	4.3	Check the drive wheel and bearing wheels for wear and			●	
	4.4	Check wheel bearings and fixing conditions			●	
Main frame	5.1	Check if the frame is damaged			●	
	5.2	Check if the sign is complete			●	
	5.3	Check the fixing of the mast			●	
Hydraulic movement	6.1	Check the function of the hydraulic system		●		
	6.2	Check hoses, pipes and connections for tightness, sealing and damage		●		
	6.3	Check the cylinder and piston for damage, sealing and fixing			●	
	6.4	Check the load chain settings and re-tension if necessary			●	
	6.5	Visually inspect the mast roller and check the wear on the			●	
	6.6	Check the forks and load part for wear and loss			●	
	6.7	Check the fuel tank level			●	
	6.8	Replace hydraulic oil				●

List of maintenance

9.4 Maintenance, recharging and Replacement of the accumulator

The forklift must be parked in a safe location before any operation on the accumulator.

9.4.1 Maintenance Technician

Only qualified technician can perform operations on the accumulator such as recharging, maintenance and replacing. Before operation carefully read instruction, manuals including operation manual, replenishment preparation and recharging requirements.

9.4.2 Fire Prevention Measures

Never smoke or use open fire when perform operations on the accumulator. The accumulator should be away from flammable material at least two meters when storage or recharging. The location for accumulator storage should be well ventilated and equipped with fire fighting devices.

9.4.3 Maintenance of the Accumulator

- 1) Keep the nuts on every battery cell dry and clean. Tighten every terminal and cable end and brush them with grease to prevent corrosion. Naked cable ends and terminal posts should be covered with a skid-proof insulating cover.
- 2) Every two cells should be well-connected. Check the nuts on each pole, if loose, tighten the nuts.
- 3) Keep the surfaces of accumulator clean and dry. After the completion of recharging, clean spilled acid with cotton yarns or brush. And clean with wet towel if necessary.
- 4) Over recharging and over discharging should be avoided, and fast charging and insufficient recharging are also not allowed. Otherwise life span of the accumulator may be affected.
- 5) Do not put conductive objects including metal tools on the accumulator, or short circuit or even explosion may be caused.
- 6) Never spill any hazardous liquid or solid material on surfaces of the accumulator. When using a densimeter or a thermometer, make sure the surface is clean and clear.
- 7) Recharge the discharged accumulator in time. Delayed recharging may damage the accumulator. Do not delay recharging more than 24 hours.

Recharging of the accumulator may not work outdoors in cold weather. In this case, move it indoors to perform recharging.

8) If the accumulator will not be in use for a long time, it should be recharged and discharged once every month and it should be fully recharged every time.

9) During recharging or using, the liquid level of electrolyte lowers because of water evaporation, so pure water should be added.

10) If individual cell fails, identify the cause and repair the cell immediately. Replace the cell when it cannot be repaired.

11) The site for recharging should be well ventilated. It is prohibited to smoke or use open fire, avoiding the risk of hydrogen explosion.

12) The electrolyte in accumulator is toxic and corrosive. For this reason, always wear working suit and protection glasses to protect your body from contacting the electrolyte in accumulator.

13) If your clothes, skin or eyes are spilled with acid liquid in accumulator, flush with large amount of clean water. For skin and eyes, flush with large amount of clean water and seek doctor's treatment immediately. Acid spillage must be neutralized and treated immediately.

14) The weight and dimensions of the accumulator have remarkable effect on stability of the forklift. Therefore, do not modify the type of accumulator without approval from the manufacturer.

15) Never discharge in large current, for example, performs travelling and lifting simultaneously

9.4.4 Disposition of worn-out accumulators

Worn-out accumulators should be recycled according to local regulations and stored in specified zone or cast-off treatment zone. These works should be done by qualified specialized companies.

9.4.5 Attention for battery use

The life of the battery is generally about 2- 3 years. If used and maintained properly, it can be used for more than 4 years. If used and maintained improperly, it will be damaged early in a few months

The battery should be regularly checked for the height of the electrolyte during use, and the battery storage condition should be checked and supplemented in time. Battery maintenance work is relatively simple but requires patience and meticulous. Do a good job of electrolyte replenishment and

density control work, cleaning of the battery and lead-out piles, etc., which can effectively extend the service life of the battery.

Check for water in the battery box and find that the water must be drained immediately.

In addition, the battery should not be stored with electrolyte. If you want to store the used and fully charged battery for a short period of time, charge it every other month during the storage period to compensate for the self-discharge of the battery and prevent the battery plate from being vulcanized or eliminated. The battery plates are slightly vulcanized, and the battery condition is often checked.

When the battery is in use, if it is not fully charged and fully discharged, a full discharge full charge should be performed every month. This keeps the capacity of the battery and avoids sulfate of the plates.

Keep the outside of the battery clean

Check the fixing of the battery and the lead wire clamp, there should be no looseness.

Check the battery case for cracking and damage, and the pole and lead chuck should be free from burning.

Wipe the external dust of the battery with a cloth. If there is electrolyte on the surface, wipe it off with a cloth or rinse it with hot water, then wipe it with a cloth. Remove dirt and oxide from the pole head, wipe the outside of the cable and the lead clamp to remove dirt. Unblock the filler cap vent and clean it. Apply a thin layer of industrial petrolatum to the pole and lead chuck during installation.

Check the height of the battery level:

A glass tube with an inner diameter of 0.2in to 0.3in and a length of about 5.9in can be inserted vertically into the liquid addition port until the edge of the pole plate, then the upper mouth of the tube is pressed with a thumb, and the glass tube is clamped with the index finger, the middle finger and the ring finger. The height of the electrolyte in the glass tube is the height of the electrolyte in the battery above the plate, which should be 0.6-1in. Finally, the electrolyte is played back into the original cell.

Replenishing electrolyte

If the electrolyte surface is too low, the distilled water should be replenished in time. Do not add tap water, river water or well water to avoid self-discharge failure caused by impurities; do not add electrolyte, otherwise the electrolyte concentration will increase, and the battery will be shortened the Service life. Note that the electrolyte surface should not be too high to prevent the electrolyte from overflowing during charging and discharging, causing short-circuit failure. After adjusting the liquid level, charge the battery for more than 0.5 hours so that the added distilled water can be mixed evenly with the original electrolyte. Otherwise, it is easy to freeze the battery in the winter.

Check of electrolyte density

The density of the electrolyte varies with the degree of charge and discharge of the battery. The degree of decrease in electrolyte density is a manifestation of the degree of battery discharge. Measure the density of the electrolyte in each cell to see how much the battery is discharged.

(1) Measurement method: Unscrew the liquid filler cap of each cell of the battery and use a densitometer to suck the electrolyte from the filler port until the float of the densitometer floats up. When observing the reading, the density should be raised to the position of the line of sight of the eye, and the float should be in the center of the glass tube without contact with the tube wall, so as not to affect the accuracy of the reading.

If the temperature is below 25 ° C or above 25 ° C, a thermometer should be used to measure the actual temperature of the electrolyte to correct the density of the electrolyte.

(2) Correction of electrolyte density: There is a certain error in the density of the electrolyte at different temperatures, and the measured electrolyte density value needs to be corrected. The electrolyte density is based on 25 ° C. Therefore, if the temperature of the electrolyte is higher or lower than 25 ° C, every 1 ° C higher, should be added from the actual measured density value of 0.0007; otherwise, lower than 25 ° C, every 1 ° C lower, should be reduced by 0.0007; If the temperature difference is large

Can be corrected as follows:

The standard temperature of the electrolyte (25 ° C) is converted according to the following formula:

$$D_{25} = D_t + 0.0007(t - 25)$$

D25 - electrolyte density at 25 ° C

Dt - measured density of electrolyte at t ° C

T—— electrolyte temperature when measuring density

9.4.6 Storage, transportation and installation of the accumulator

The forklift must be parked on the level ground steadily. To prevent short circuit, naked cable ends and the terminal posts should be covered with insulated covers. When pulling out the accumulator, properly arrange removed accumulator's connectors and cables without blocking access of the accumulator.

When install or remove the accumulator with a crane, make sure the load capacity is sufficient (weight of the accumulator is marked on both the nameplates of the accumulator and the forklift.) The crane must pull vertically to prevent the battery box from being damaged. The hooks of the crane should be safe and secure. Never let the hooks fall on an individual battery .

— Press emergency stop switch and turn the power supply switch to OFF position

— Remove the connectors of accumulator cables.

—Connect the lifting device to lifting holes.

—Lift out the accumulator from the top and move away with handling equipment.

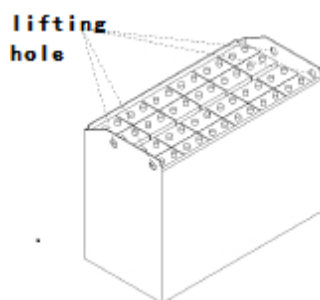

Perform installation in reverse order of above steps. It is noticeable to put the accumulator in right position and connect the cables securely. After reinstalling the accumulator, always check all cable connections and connectors for obvious damage.

9.4.7 Battery Charging

(1) Initial charging (the company's products are generally pre-charged; users cannot do this operation)

The quality of the initial charge has a great influence on the battery, and it must be operated by an experienced personnel .

The unused battery should be charged before use.

Clean the surface of the battery before initial charging and check for damage.

Open the lid on the filler cap to ensure that the venting hole is clear.

Under the condition that the charger can work normally, the sulfuric acid electrolyte with a density of 1.26 ± 0.005 (25°C) and a temperature lower than 30°C is poured into the battery, and the liquid level requirement is 15 to 25 mm higher than the protection plate.

Allow the battery to stand for 3 to 4 hours, no more than 8 hours. The initial charge can be performed until the liquid temperature drops below 35°C . If the electrolyte surface drops after standing, the electrolyte should be replenished.

The sulfuric acid electrolyte is prepared by using the battery sulfuric acid and steamed water in accordance with the national standard GB4554-84 (do not substitute industrial sulfuric acid or tap water).

During the preparation, only concentrated sulfuric acid can be slowly injected into the distilled water in a fine flow, and it is continuously stirred with an acid-resistant glass rod or a lead-coated wooden stick. Never allow distilled water to be injected into the sulfuric acid, otherwise the solution will boil and splash, causing burns accident.

The connection line between the charger and the battery requires the correct polarity, that is, the positive pole is connected to the positive pole and the negative pole is connected to the negative pole, and the connection is required to be reliable.

The first stage of initial charging uses 0.5I5A (60A for D-600 batteries) and charges until the battery voltage reaches 2.4V.

Enter the second stage of initial charging;

The second stage of initial charging uses 0.25I5A (30A for D-600 batteries);

The temperature of the electrolyte during charging should not exceed 45 ° C. When the temperature is close to 45 ° C, the charging current should be halved or suspended.

Continue charging after the electrolyte temperature drops below 35 ° C. However, it is necessary to extend the charging time appropriately;

The basis of sufficient power: in the second stage of initial charging, the voltage is up to 2.6V, the voltage change is not more than 0.005V; the density of the electrolyte reaches 1.28 ± 0.005 (25 ° C), there is no obvious change within 2 hours and there are fierce bubbles. When it happens, the battery is considered fully charged. The charging capacity is 4 to 5 times of the rated capacity, and the charging time is about 70 hours;

In order to accurately control the content of sulfuric acid in the electrolyte, the density of the electrolyte of each battery should be checked at the end of charging; if there is any discrepancy, it should be adjusted with distilled water or sulfuric acid with a density of 1.40 and should be within 2 hours of charging. Adjust the density and liquid level of the electrolyte to the specified value;

After the initial charging is completed, wipe the surface of the battery clean and cover the filling port before putting it into use.

(2) Ordinary charging

Uncharged batteries are not available. The battery should pay close attention to the degree of discharge during use. If the discharge exceeds the specified level, it should be charged. It is necessary to prohibit excessive discharge - that is, the voltage drops to 1.7V / only, when the electrolyte density drops to 1.17, the discharge should be stopped and charged in time, and should not be left for a long time. The charging should not stop during the charging process without any reason

When performing normal charging, first open the lid on the filling port cover to check whether the electrolyte is at the specified height. Otherwise, use distilled water to adjust the liquid level of the battery to the specified height.

Connect the output of the charger to the battery as required. The positive pole is connected to the positive pole and the negative pole is connected to the negative pole.

The charger matched with the battery can automatically adjust the charging current according to the state of charge of the battery until the battery is fully

charged. (For the observation of the charging status, please refer to the manual of the charger)

To understand the condition of the battery in time, it is recommended to establish a charge and discharge record for each battery, so as to provide a useful basis for the judgment of the failure of the battery in the future. During the charging process, measure and record the current, total voltage, voltage of each single cell (to be numbered), electrolyte density and temperature (a mercury thermometer with 0 to 100 ° C) changes every 1-2 hours.

When the electrolyte has many even and fine bubbles, the cell voltage is stable at 2.5-2.7V, and the electrolyte density and terminal voltage do not continue to rise within 2-3 hours, indicating that the battery is fully charged. If individual units are weak or do not produce fine bubbles, the cause should be identified and processed and recorded in the work log.

The temperature of the electrolyte during charging should not exceed 45 ° C. When it is close to 45 ° C, the charging should be suspended; wait until the electrolyte temperature drops below 35 ° C before charging.

When the battery is charged, check the electrolyte density of the battery. If the electrolyte density does not meet the requirements, the electrolyte in the original cell can be extracted first. If the original density is too small, it can be adjusted by adding a concentrated electrolyte with a density of 1.40. If the original density is too large, distilled water can be added for dilution. The adjusted density of each single cell electrolyte should not exceed 0.01, and the liquid level should meet the requirements. After the density is adjusted, continue charging for a small current for 0.5 hours to make the electrolyte evenly mixed. Then check the electrolyte density and adjust if necessary. Finally, wipe the battery clean and use it for loading.

(3) Balanced charging

Under normal circumstances, although the entire battery pack of the battery pack is operated under the same conditions, it may cause imbalance of the entire battery pack for some reason. In this case, a balanced charging method should be used to eliminate the battery between the batteries. The difference is to achieve a balanced battery. The balanced charging method is simple and can be operated according to the charger manual.

The battery that is normally used is charged once every 2 to 3 months. A battery that has not been used for a long time should be balanced charged before use.

10、 Safety caution

10.1 General rule

10.1.1 Requirements for drivers: The operator must have the operating qualification of the forklift (approved by the relevant department) before driving the forklift

10.1.2 The operator must read the entire contents of the instruction manual before using it and drive the truck after fully understanding the operation method.

10.1.3 The forklift truck must not carry passengers.

10.1.4 Operators should pay special attention to the operating environment during work, including other people in the vicinity and other objects.

10.1.5 Do not modify, add or disassemble the moving parts without the manufacturer's approval, so as not to affect its performance.

10.2 Transportation and storage

10.2.1 When shipping in containers or cars, please note:

① The front and rear wheels are fixed with a wedge to prevent sliding during transportation.

② When using the lasso, pay attention not to put on the fragile structure of the moving forklift;

③ When using the truck, keep the center of gravity of the truck in the middle of the fork.

10.2.2 When the van is not working, it should be parked in a dry and ventilated garage to prevent the sun and rain, and please note:

① Turn off the electric lock, cut off the power and unplug the power plug;

② After pulling up the stationary truck, the front and rear wheels are well padded.

③ In case of long-term disuse, the battery should be replenished every 15 days.

10.3 Check before Using

10.3.1 If the new forklift is damaged during transportation, please do not put it into use and contact the supplier in time for proper treatment.

10.3.2 New forklift have been equipped with lubricating oil and hydraulic oil in the fuel tank.

10.3.3 Storage battery for the moving forklift. The battery has been charged at the factory. If the factory is long, the power may be low. Attention should be paid to the display of the electric meter before use. When the electric meter is shown to the last two bars of warning, it must be charged immediately. Open the battery cover every day before use or before charging. Check the level. If the level is too low, distilled water should be added before charging. See (battery charging and maintenance) for details.

10.4 Safe Operation

10.4.1 Requirements for drivers: The forklift must be operated by a trained staff. He can demonstrate the operation of the goods to the users and can clearly guide the user how to operate the forklift.

10.4.2 Drivers' rights, obligations and responsibilities: Has been trained by the operation of the vehicle, the driver must be clear of his rights and obligations; and he is familiar with the contents of the relevant operating instructions. If the vehicle is pedestrian, the driver must also wear safety boots.

10.4.3 Prohibit unauthorized personnel to operate: the driver is responsible for the vehicle at work. He must prevent unauthorized persons from driving or operating this vehicle. It is forbidden to use the vehicle to transport or lift personnel.

10.4.4 Malfunctions and defects: There is any malfunction or defect for the vehicle, must immediately inform management. If the vehicle cannot be

safely operated (e.g.: wheel wear or brake failure), then it must stop using until it is fully repaired.

10.4.5 Safe operation and environmental protection: inspection and maintenance must be performed in accordance with the time intervals on the maintenance list.

Parts of the forklift cannot be changed without any permission, especially safety devices. The operating speed of the forklift is not allowed to change.

All original spare parts have been verified by quality assurance department. To ensure the safety and reliability of the operation of the vehicle must use only the manufacturer's spare parts. The old parts, such as oils and fuels must be handled in accordance with the relevant environmental protection rules.

10.4.6 Hazardous area: Hazardous area usually refers to the following range: forklift or its load lifting devices (e.g. fork or accessories) is dangerous for personnel when running or lifting movements, or the ongoing regional transport loads. Typically, this range extends to the load or vehicle accessories landing area.

Unauthorized personnel must be asked to leave the dangerous zone. If the situation might cause some kind of damage, the driver must give a warning, if the driver asked the person to leave but did not leave the danger zone, the driver must immediately stop the forklift

10.4.7 Risk environment: When working in high-risk environment, you must have a distinctive design to be protected

The forklift was not specially designed for the high-risk environment.

10.4.8 Safety devices and warning signs: Safety devices, warning signs and warning notes described in the previous operating instructions must be taken seriously enough.

10.4.9 Driving in public places: the forklift is forbidden to drive in public places other than specific areas.

10.4.10 distance between forklift: Keep in mind that the forklift in front could suddenly stop at any time, so please keep an appropriate distance.

10.4.11 headroom: When the headroom is below the cargo or mast, it is prohibit using the forklift.

10.4.12 the use in the elevator and loading platform maneuvering: if there is enough loading capacity, does not affect the operation of the vehicle, and agreed by the user of the forklift, lift and loading platform that can be used for forklift transport. Before entering the elevator or loading station, driver must personally identify. The goods must be placed in front and occupy an appropriate place, when the forklift enters the elevator, so as not to contact with the walls of the elevator. When personnel and vehicles take the elevator together, personnel must enter after the forklift safety entered, and personnel must leave before the forklift.

10.4.1 with access and working area: The forklift must be operated on the specified channel, all the non-related personnel must leave the work area, and cargo should be stacked in designated places.

10.4.14 Operations Management: traveling speed must be adapted to local conditions. When through the corners, narrow passage, swing doors and closed place, the vehicle must slow down. Drivers must be able to visually an adequate braking distance between the vehicle and the vehicle in front, and he must remain in control of his forklift. Sudden stop (unless urgent needs), rapid U-turn, chased each other in the channel is not allowed in not smooth places. It is forbidden to operate while the body is lean outside.

10.4.15 Visibility: The driver must look in the direction of travel, to ensure that the front situation is clearly visible. When the vehicle is backing up with the carriage of goods blocked the line of sight, there is must be a second person walk in front of the forklift to give appropriate guidance and warnings.

10.4.16 via the ramp: Only known ramp could go through. While the ramp should be clean, non-slip, and the forklift technical specification includes the ramp. The goods on the forks must face uphill. It is forbidden to turn back, move diagonally or park on the ramp. The driver must slow down when going through the ramp and prepare to brake at any time.

10.4.17 ground load: Remember to check the load pressure of the body weight or wheels on the ground does not exceed the capacity of the ground, when the vehicle is in operation.

10.4.18 Forklift Change: any possible changes or modifications for rated load, stability or safe operation of the forklift, must obtain prior written approval from origin manufacturers or its successor. After vehicle manufacturer check and

approve the changes, nameplates, labels and markings of Operation and Maintenance Manual must be modified as well

11、 Service Manual

11.1 Hand and foot brake common faults and troubleshooting

Fault	Cause	Troubleshooting
Poor braking	1、 Improper brake pedal position	Adjust it
	2、 Brake system oil leakage	Overhaul or replace
	3、 Air is mixed in the brake system	exhaust
	4、 Brake shoe clearance is not adjusted	Adjust it
	5、 Deformation, damage or excessive wear of the pump sub-pump	Check the cause of the damage and replace it
	6、 There is oil on the surface of the brake drum hole	Clean it
Brake uneven	1、 Oil on the surface of the friction plate	Clean and replace it
	2、 Brake drum hole deviation, Large hole with different center	Large holes ensure roundness and concentricity
	3、 Brake shoe clearance is not adjusted	Adjust it
	4、 Brake shoe return spring damage	replace it
	5、 Sub-pump failure	Adjust or replace it
	6、 Self-regulating mechanism failure	Reset spring deformation, repair, replacement
Brake noise	1、 he friction plate is hardened or has impurities	replace it
	2、 Bottom plate deformation or loose bolts	Repair it
	3、 Brake shoe is deformed or incorrectly installed	Replace or repair
	4、 Friction plate excessive wear	replace it
	5、 Loose hub shaft	replace it
Other bad brakes	1、 Brake overheating	Check if it is slippery

	2、 Impurities are mixed into the brake fluid	Check and replace brake fluid
	3、 Hand brake position cable deformation, joint dropout	Replace or repair

11.2steering system common faults and troubleshooting

Fault	Cause	Troubleshooting
Steering issue	1、 There is air on Steering system hydraulic line components	Exhaust air
	2、 oil level is too low ,inhaling air	Add oil and exhaust air
	3、 The divert valve hole is blocked and the spool is stuck	Clean and replace
	4、 Steering cylinder piston rod bending	Replace the piston rod
	5、 Knuckle and steering pin seizure	Inspection method: Lifting the rear axle to see if the left and right swing is flexible
	6、 Other relative surfaces when turning seizure	
	7、 The ball in the steering valve body fails and blocks	Demolition, repair
	8、 Steering gear reset failure, spring piece break	Replace the spring piece
	9、 steering cylinder leakage is too much	Check the piston seal and replace
	10、 Shunt valve pressure is lower than working pressure, flow rate is too low	Adjust pressure and flow
	11、 Oil viscosity is too high	Use specified oil
	12、 Excessive wear of the valve core and valve body, excessive clearance	replace
	13、 Excessive wear of the oil pump	replace
Oil spill	1、 The joint is not tight	Tight the joint
	2、 Steering valve body spacer stator and back cover joint surface is dirty	Clean
	3、 Cylinder leakage	Check the seal of the guide sleeve seal joint
Abnormal noise	1、 Tank oil level is too low, hydraulic noise	Add oil and exhaust air

	2、 Suction tank or oil filter plugged	Clean and replace
--	---------------------------------------	-------------------

11.3lifting system common faults and troubleshooting

Fault	Cause	Troubleshooting
Lifting, lowered is not stable, loud noise	1、 The gap between upper end roller of outer mast and channel steel of inner mast is too large > 1mm	Reduce adjustment gasket
	2.The gap between the lower end roller of the outer mast and the channel steel of the inner mast is too large > 1mm	increase adjustment gasket
	3、 The clearance between the side roller of the fork frame and the channel of the inner mast is too large >1mm	Reduce adjustment gasket
	4、 Side roller shaft fastening bolt loose	tighten
	5、 Slide frame, inner mast channel steel with debris	Clearly, add oil regularly on the track.
The fork frame is skewed	1、 Inconsistent tire pressure on the left and right sides	Fill air, pressure is consistent
	2、 Left and right chain tension is inconsistent	Consistent tightness adjustment
	3、 Oil passage blockage in speed limit valve	Clean and replace
	4、 Part of the lift cylinder inlet is blocked	Overhaul, cleaning
Left and right lifts are not synchronized	1、 The left and right lift cylinders are inconsistent	180-degree adjustment with the cylinder head
	2、 The left and right cylinder heights are inconsistent	Adjust with the adjusting bolt on the cylinder
	3、 The left and right cylinder strokes are not consistently larger than the cylinder head adjustment range	Adjusting washer on the piston rod of the lifting cylinder
Full load super-liter speed does not meet the specified requirements	1、 Insufficient working oil	Add oil
	2、 he throttles orifice of the speed limit valve is blocked by the dirt	Unpick and wash
	3、 The safety valve is slippery	Cleaning, repair

Or can't lift	and stuck	
	4、 Oil leakage in the suction pipe of the filter in the fuel tank	Repair welding, bottom leakage
	5、 Loose pipe joint	tighten
	6、 Oil pump gear and pump body are excessively worn, and the clearance is too large	Check the cleanliness of the oil, requiring 9-11
	7、 Lift cylinder inner sealing ring damage or excessive wear excessive leakage	Replace the sealing ring
	8、 The clearance between the valve body and the spool of the multi-way valve is too large, and the pressure of the main valve is too low.	Replace and adjust
	9、 Diverter valve is improperly diverted	Adjust

11.4 Electrical system common faults and troubleshooting

Turn on the key switch without voltage	<ul style="list-style-type: none"> 1、 Poor contact of the key switch 2、 break line 3、 Poor contact of connectors 4、 Loose battery connector
Stepping on the accelerator pedal, the forklift does not move	<ul style="list-style-type: none"> 1、 break line 2、 Poor contact of connectors 3、 Poor contact of the direction switch 4、 The thyristor speed regulating device broke down
The lifting motor does not work	<ul style="list-style-type: none"> 1、 The contactor coil is broken or open 2、 Lift switch does not work properly 3、 break line 4、 Poor contact of connectors 5、 The main contact of the contactor burns out
Lifting motor long turn	<ul style="list-style-type: none"> 1、 Lift switch does not work properly
The light does not work properly	<ul style="list-style-type: none"> 1、 Fusible wire break 2、 Poor contact of connectors 3、 Bad bulb
The speaker does not ring	<ul style="list-style-type: none"> 1、 Poor contact of connectors 2、 Poor contact of the horn switch 3、 bad horn

Horn rang for long time	1、 Horn switch contact long pass
Reversing buzzer does not ring	1、 bad reversing buzzer 2、 Poor contact of the reverse switch 3、 Poor line connection

11.5 Gearbox common faults and troubleshooting

fault	troubleshooting
Efficiency droop	1.The friction plate is stuck or worn. Check the friction plates for gluing, uneven contact or warpage.
	2.The bearing is damaged. Replace the bearing.
	3.Check if the lubrication circuit is blocked.
Oil spill	1.The gasket is broken. Replace the gasket.
	2Rubber parts are aged or damaged. Replace parts.
	3The part is damaged and cracked. Replace it.

11.6 Multi valve common faults and troubleshooting

Fault	Cause	troubleshooting
External leakage	1.Lip seal wear 2.Damage to the stem seal 3.The lip seal is embedded with foreign matter such as paint and dust. 4.O-ring seal damaged (cut ring) 5.Aging deformation of the seal between the valve plates 6.The valve seal surface is scratched (new valve) or has foreign matter 7The valve body hole is not the same as the seal ring hole (new valve) 8.The back pressure of oil return exceeds the allowable value 9.Inter-plate studs are unevenly stressed or not tightened	1.Replace the lip seal 2.Replace stem or disc assembly 3.Clean foreign matter such as paint embedded in the seal of the lip, taking care not to damage the stem and sealing surface. 4.replace O -ring seal 5.Replace the new seal 6.Remove foreign objects or replace the valve 7.replace the valve 8.Check the circuit and reduce the return oil pressure to the specified value 9.Tighten the studs as required

<p>Valve stem cannot be reset</p>	<ol style="list-style-type: none"> 1.The operating mechanism is not flexible when stuck 2.Stem jammed with dirt 3.Return spring deformation or fracture 4.External force causes deformation of the stem 5.The mounting surface is uneven, and the valve body is deformed, causing the valve to be stuck. 	<ol style="list-style-type: none"> 1Check the operating lever 2.Cleaning valve, fuel tank and piping 3.Remove the back cover and replace the spring 4.Replace stem or valve assembly 5.adjust mounting plane
<p>Stem drops at neutral weight (excessive leakage in valve neutral position)</p>	<ol style="list-style-type: none"> 1.Valve stem and valve hole wear, gap increases, internal leakage is serious 2.Stem or hole with scratches to increase internal leakage 3.The stem is not return to neutral position 4.Overload valve or overload valve screw plug and valve body seal is not tightly sealed 5.Severe leakage inside the cylinder 6.Valve body groove size out of line sealing oil length decreases 	<ol style="list-style-type: none"> 1.Reconfigure stem 2.Replace stem or valve assembly 3.Check the reversing mechanism 4Check if the O-ring is cut, if it is damaged, replace it with a new O-ring 5.Check the cylinder piston seal for damage 6.Replace the valve
<p>Hard steering</p>	<ol style="list-style-type: none"> 1.The oil is not clean, the split spool or the split safety spool is stuck by foreign matter 2.The opening and closing characteristics of the shunt safety valve are not good or the pressure regulation of the shunt safety valve is low 3.Insufficient pump flow 4.Steering gear malfunction 	<ol style="list-style-type: none"> 1.Cleaning the split spool or split safety spool and tank and piping 2 Replace the diverter relief valve or re-adjust the diverter relief valve pressure 3.Check why the oil pumping system is insufficient 4.replace the steering gear
<p>No action in the cylinder (low pressure or no pressure)</p>	<ol style="list-style-type: none"> 1.There is a foreign matter stuck between the main valve core of the relief valve or the overload valve and the valve seat. 2.Damping hole blockage 3.Cone spool has abnormal wear 4.Pressure regulating spring deformation 5.Overflow valve adjustment screw 	<ol style="list-style-type: none"> 1.Cleaning valves, fuel tanks, piping, etc. 2.Serious hydraulic oil pollution, cleaning hydraulic system 3.Check for wear and replace the overflow valve assembly 4.Check spring quality 5.After adjusting the pressure

	loose 6.oil pump malfunction	again, tighten the nut to the specified torque. 6.replace oil pump
Overflow valve has vibration and noise	1.Air in the hydraulic system 2.Oil pump suction air 3.Suction pipe resistance is too large or the oil pump suction side of negative pressure 4.Suction oil filter plugged 5.The relief valve has a pressure point vibration and noise	1.The system is repeatedly operated for a while and then discharged. 2.Check oil pump suction test 3Check the cause of negative pressure 4.Clean the oil filter and filter the oil 5.Adjust the overflow valve, slightly increase or decrease the pressure gauge 1~2 scales
Tilting forward without self-locking or overlocking	1.The oil is not clean, so that the forward tilt control small spool is stuck 2.Connected to the wrong port	1.Cleaning valves, fuel tanks, piping, etc. 2.Turn over the wrong oil port

11.7Gear pump common faults and troubleshooting

Fault	Cause	Troubleshooting
Pumping does not enter oil or oil absorption is not smooth	1.Suction oil filter has a small flow area or is blocked by foreign matter 2.Tank level is too low 3.High installation position of oil pump; The suction range exceeds the regulation 4.The oil temperature is too low, and the viscosity of the oil is too high 5.Suction tube is too thin or too long, too much resistance 6.The oil seal of the oil pump is	1.Replace the oil filter with a suitable flow area or clean the blocked oil filter 2.The fuel tank is filled with hydraulic oil as required 3.According to the suction stroke of the oil pump, within 500mm. 4.Change the appropriate oil or heating oil by season 5.Change the large diameter oil pipe to shorten the length of the suction pipe 6.replace oil seal

	<p>damaged, and the air is taken in.</p> <p>7.Oil pump is not in the wrong direction or the speed is too high</p> <p>8.Oil leakage on the suction side</p>	<p>7.Change the direction of the oil pump to make the speed to the specified value</p> <p>8Check the oil suction part and its seal, replace the failed seal</p>
There is no oil coming out of the oil discharging side of the pump	If it is not for the above reasons, the pump has been damaged or the overflow valve is damaged or jammed, and the oil flows back from the overflow valve to the tank.	<p>1.Check and repair the pump or replace it with a new one</p> <p>2.Check and repair the relief valve or replace the relief valve, filter the oil or change the fluid</p>
Oil is discharged from the outlet of the oil pump, but the pressure cannot go up	<p>1.the side plate of the oil pump is seriously worn and the volumetric efficiency is too low.</p> <p>2.The cone spool of the overflow valve is badly</p> <p>3.The overflow valve is jammed by stolen goods and does not close tightly</p> <p>4.Overflow valve pressure is too low</p> <p>5.Suction port inhaling air</p>	<p>1Repair or replace the oil pump</p> <p>2.Replace the new poppet</p> <p>3.Filter oil to remove dirt</p> <p>4.Adjust the relief valve to the specified value</p> <p>5.Check the seal at the suction port for damage</p>
Oil pump volume efficiency is low	<p>1.Seal of oil pump is damaged</p> <p>2.Side panel wear</p> <p>3.There is a dirt or gap in the oil pump</p> <p>4.Oil pump speed is too low or too high</p> <p>5.Negative pressure inside the fuel tank</p>	<p>1.replace the seal</p> <p>2.replace the side panel</p> <p>3.Remove dirt, filter oil; replace new oil pump</p> <p>4.Operating the oil pump within the specified speed range</p> <p>5.Increase the capacity of the air filter</p>
Noise from oil pump	<p>1.Most cases are caused by insufficient oil absorption by oil pump, such as blockage of oil absorption filter; Oil level is too low; Inhalation of air; Oil seal suction air, etc</p> <p>2.The return pipe is higher than</p>	<p>1.Keep the oil level high, the seal must be reliable to prevent oil contamination</p> <p>2Immerse the return pipe below the oil level</p> <p>3.Select the appropriate viscosity of the oil according to</p>

	<p>the oil level, and there are a lot of bubbles in the oil.</p> <p>3.The viscosity of the oil is too high, and the oil temperature is too low</p> <p>4.The coaxially between the pump shaft and the prime mover shaft is too large</p> <p>5.After maintenance, the driven gear is loaded upside down and the meshing area becomes smaller</p>	<p>the season, or heating</p> <p>4.Adjust the coaxially of the two axes</p> <p>5.Disassemble the oil pump and turn the driven gear around</p>
Oil pump temperature rises too high	<p>1.The pressure is too high, the speed is too fast, and the side plate is burnt</p> <p>2.Oil viscosity is too high or internal leakage is severe</p> <p>3.Back oil pressure is too high</p> <p>4.The oil tank is too small, and the heat dissipation is poor</p>	<p>1.Adjust the relief valve appropriately; reduce the speed to the specified value; repair the oil pump</p> <p>2.Change the oil and check the seal</p> <p>3.Eliminate the cause of excessive oil back pressure</p> <p>4.Increase the fuel tank</p>

11.80ther common faults and troubleshooting

Fault	Cause	troubleshooting
Abnormal sound during moving	1、 The amount of oil such as hydraulic oil and gear oil does not meet the	Fuel to the required level
	2、 Front and rear hub bearings are loose and broken	Tighten the bearing and lock the nut back to about 1/8 turn. The hub should be free to
	3、 Gearbox, gear, friction plate damage	replace
	4、 Differential and cross shaft damage	replace
	5、 Loose fasteners	tighten

12.After-sales service

If there is a problem that cannot be solved by professional maintenance staff, please contact our after-sales service staff at (877)232-6517